



MODEL: ER32L65
Lithium Thionyl Chloride
(Li-SOCl₂) Battery

ELECTRICAL CHARACTERISTICS

(typical values for cells stored for one year or less, at 25°C)

<p>■ Nominal capacity (at 1.0 mA, +25°C, 2.0V cut off. The capacity restored by the cell varies according to current drain, temperature and cut off voltage.)</p>	1.0 Ah
<p>■ Rated voltage</p>	3.6 V
<p>■ Maximum recommended continuous current (To get 50% of the nominal capacity at +25°C with 2.0V cut off. Higher currents possible. Consult OmniCel.)</p>	10 mA
<p>■ Maximum pulse current capability Rated 1 sec. pulse capability(to 3V) Pulse capability varies according to pulse characteristics (frequency and duration), temperature, cell history (storage conditions prior to usage) and the application's acceptable minimum voltage.</p>	50mA 20mA
<p>■ Storage (recommended) (for more severe condition consult OmniCel.)</p>	30°C max
<p>■ Operating temperature range (Operation at temperature different from ambient may lead to reduced capacity and lower voltage plateau readings.)</p>	-55°C / +85°C

⚠ WARNING:

Fire, explosion and severe burn hazard. Do not recharge, crush, disassemble, heat above 212°F (100°C), incinerate, or expose contents to water.

KEY FEATURES

- ✓ High and stable operating voltage
- ✓ High minimum voltage during pulsing
- ✓ Low self discharge rate (less than 1% after 1 year of storage at +25°C)
- ✓ Stainless steel container
- ✓ Hermetic glass-to-metal sealing
- ✓ Non-flammable electrolyte
- ✓ Non restricted for transport
- ✓ Compliant with IEC 86-4 safety standard and EN 50020 intrinsic safety

UL Underwriters Laboratories (UL) Component Recognition (File Number MH28717)

MAIN APPLICATIONS

- ✓ Utility metering
- ✓ Alarms and security devices
- ✓ Memory back-up
- ✓ Tracking systems
- ✓ Automotive electronics
- ✓ Professional electronics ... etc.

Note: Any representations in this data sheet concerning performance are for informational purpose only and are not construed as warranties, either expressed or implied, of future performance.

DISCHARGE CHARACTERISTICS @ + 25°C

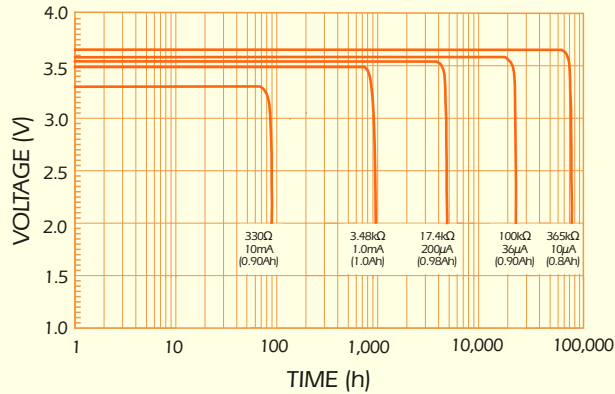

ER32L65

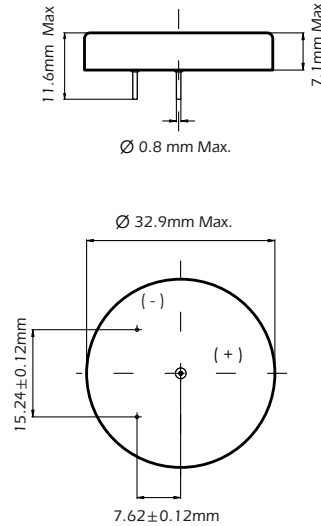

AVAILABLE TERMINATIONS

Suffix -/P

Tinned Nickel Pins

VOLTAGE VS. TEMPERATURE

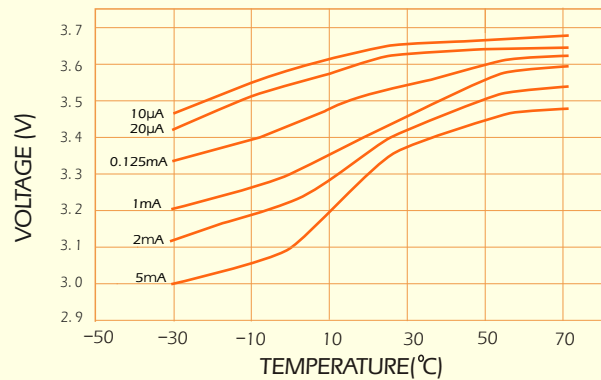

PHYSICAL CHARACTERISTICS

- Diameter (max) 32.9 mm (1.295")
- Height (max) 7.1 mm (0.256")
- Typical weight 19 g (0.670oz)

CAPACITY VS. CURRENT

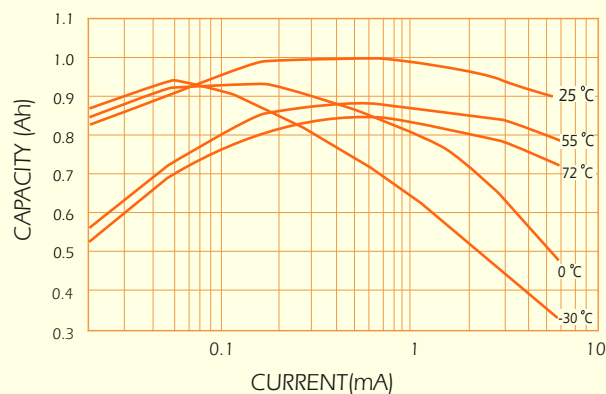

STORAGE CHARACTERISTICS

